

Closed Ion Source Gas Analyzers

CIS100/200/300 — 100, 200 and 300 amu systems



CIS Series Closed Ion Source Gas Analyzers

- **100, 200 and 300 amu systems**
- **1 ppm detection**
- **10 mTorr max. operating pressure**
- **1×10^{-12} Torr detection limit**
- **RGA Windows software**
- **Field-replaceable electron multiplier and filament**
- **RGA and CIS mode**

With better than 1 ppm detection limit, direct sampling at mTorr pressure, and a user-friendly Windows software package, the CIS systems will satisfy your most demanding applications. On-line process monitoring and control, verification of process gas purity at the point of use, high-vacuum residual gas analysis, and process equipment leak checking are some of the areas where these systems will prove indispensable.

Compact Design

The probe consists of a quadrupole mass spectrometer with a CIS ionizer mounted inside a 2.75" Conflat® Tee. The control unit mounts directly on the probe's feedthrough flange and contains all the necessary electronics for operating the instrument. The side port of the CIS nipple provides a connection for the differential pumping system that keeps the quadrupole, filament and detector at high vacuum. The system can be connected directly to a process chamber through its standard CIS mounting flange (2.75" CF). All parts in the unit are self-aligning making servicing easy. You can clean and reassemble the probe, and replace the filament and electron multiplier in the field, without ever calling the factory.

Gold Plated Ionizer

The entire ionizer is made of gold-plated stainless steel. This reduces outgassing and background signals in the ionization region, improves long-term stability, and permits operation

CIS100/200/300 Closed Ion Source Gas Analyzers

while exposed to reactive and corrosive gases. A tungsten filament is used, which resists corrosive and reactive gases



CIS gold plated ionizer

like WF_6 and silane, and leads to extended lifetime. The closed (gas tight) design of the ionizer prevents commonly interfering species from backstreaming into the ionization volume. This produces peaks free of spectral overlap.

A Choice of Detectors

The CIS series analyzers come standard with both a Faraday cup detector (10 ppm detection) and a continuous dynode electron multiplier (1 ppm detection). The software allows you to easily switch between detectors.

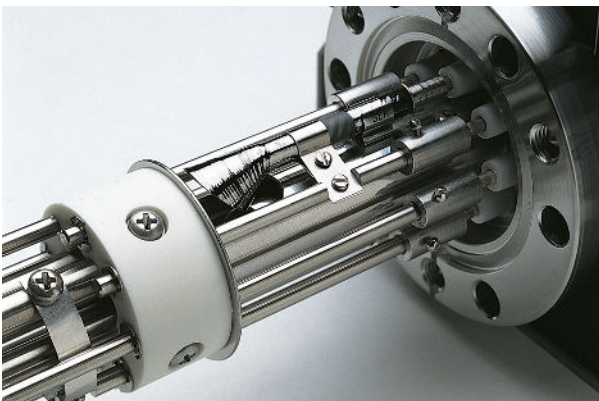

Continuous dynode electron multiplier

Versatility

The CIS systems can also be used in a so-called “RGA mode”. In this mode, the unit has a lower minimum detectable partial pressure, but a lower maximum operating pressure as well. The RGA mode is used, for example, in the first stage of a sputtering process when the chamber is evacuated to a low pressure, and the quality of the vacuum is checked for leaks and harmful contaminants. The unit can then be switched to a CIS mode for sampling directly at higher pressure.

Complete Programmability

A standard RS-232 interface is provided along with a complete programming reference. All probe parameters can be controlled and monitored, and data can be acquired for use in custom applications.

Windows Software

The CIS systems are supported with a real-time Windows software package that runs on PCs. The intuitive, graphical user interface allows measurements to be made quickly and easily. The program is fully interactive, giving the user complete control of the graphical display. Screens can be split for dual-mode operation, scales can be set to linear or log format, and data can be scaled manually or automatically. Data is captured and displayed in real time or scheduled for acquisition at a given interval for long-term data logging. Features include user-selectable units (ppm, Torr, mbar, Pa and A), programmable audio and visual

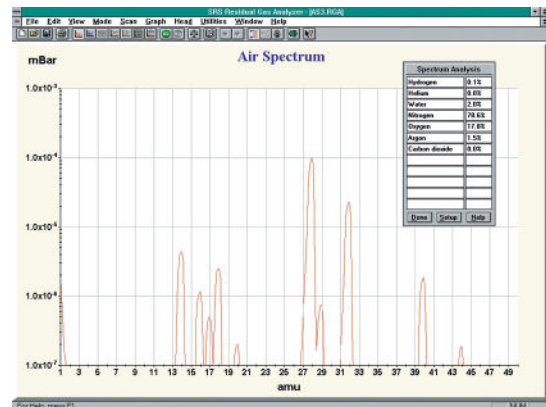

RGA Windows software— Analog mode

alarms, and comprehensive on-line help. The software allows complete CIS head control with easy mass scale tuning, sensitivity calibration, ionizer setup, and electron multiplier gain adjustment. For further analysis, data files can be saved

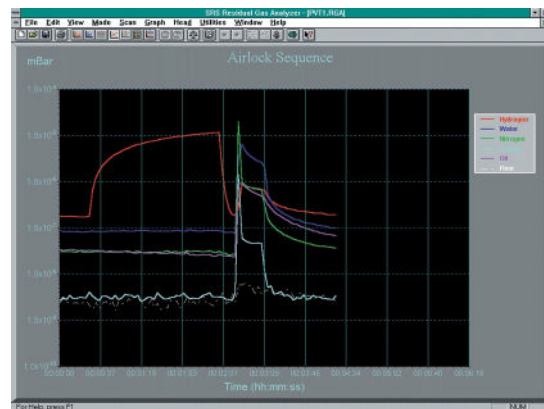

RGA Windows software— P vs. T mode

in ASCII format for easy transfer into spreadsheets. Graphic images can be saved as META files or copied to the clipboard

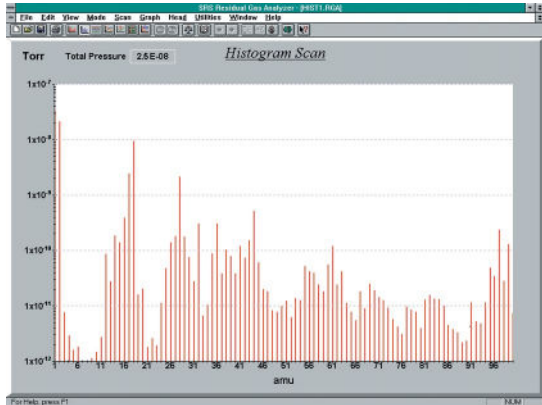

RGA Windows software—Histogram mode

for importing into other Windows programs. The software also provides password protection for locking out head parameters so that casual users can't alter important settings.

An optional stand-alone monitor (PPM100) can be used to control the RGA without a host computer.

Multi-Head Operation

The software supports multiple head operation when more than one CIS is needed. Up to eight ECUs can be monitored from the software.

Pumping Requirements

The CIS instruments require connection to a pumping system with an effective pumping speed of at least 40 L/s and a base

pressure of less than 10^{-9} Torr. The connection port is a 2.75" CF flange. Option O100TDP provides a turbo pump which mounts directly to the CIS head along with a diaphragm roughing pump. When this option is ordered, the entire analyzer is assembled, tested, and calibrated at the factory. Users can provide their own pumping station; however, it is the user's responsibility to ensure that the pumping system does not damage or limit the performance of the instrument.

Affordable Performance

The SRS CIS systems offer state-of-the-art performance for a fraction of the cost of competing models. Standard systems include faraday cup detector, electron multiplier detector and Windows software. Options include built-in power module for AC line operation, and a pumping package that includes a turbomolecular pump and diaphragm pump.



CIS rear panel (without AC power module)

CIS rear panel (with AC power module)

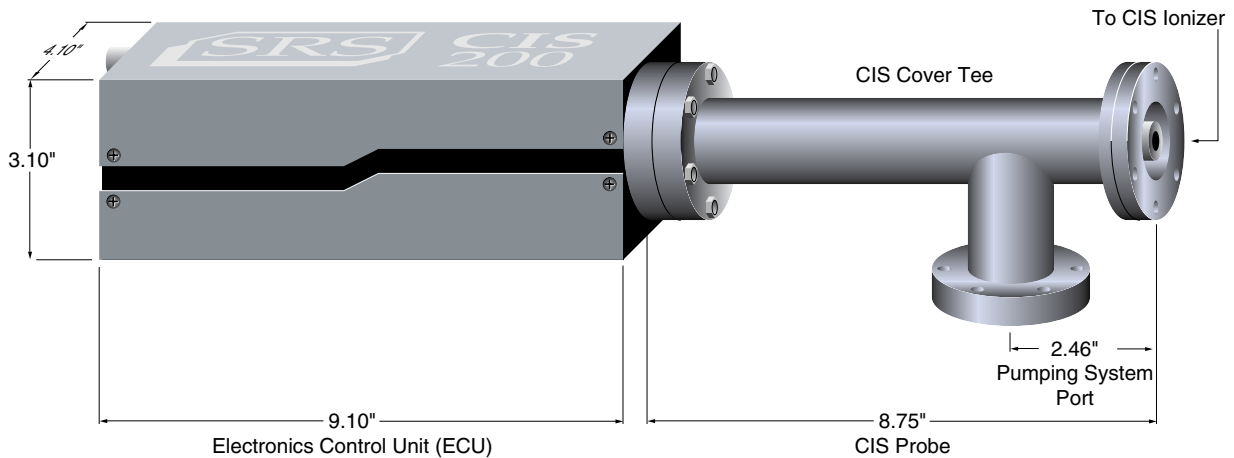

CIS dimensional drawing

CIS100/200/300 Specifications

Operational

| | |
|----------------------------------|---|
| Mass range | |
| CIS100/1 | 1 to 100 amu |
| CIS200/1 | 1 to 200 amu |
| CIS300/1 | 1 to 300 amu |
| Mass filter type | Quadrupole |
| Detector type | Faraday cup and electron multiplier |
| Resolution (per AVS std. 2.3) | Better than 0.5 amu @ 10% peak height. Adjustable to constant peak width throughout mass range. |
| Operating temperature | 70 °C (max.) |
| Bakeout temperature | 300 °C (without ECU) |

Ionizer

| | |
|---------------------------|---|
| Design | Closed ion source, cylindrical symmetry, electron impact ionization. |
| Material | Gold plated SS304 |
| Filament | Tungsten or ThO ₂ /Ir with firmware protection (field replaceable) |
| Electron energy | 25 to 105 eV, programmable |
| Ion energy | 4 or 8 eV, programmable |
| Focus voltage | 0 to 150 V, programmable |
| Electron emission current | 0 to 1 mA, programmable |

General

| | |
|-----------------------|--|
| Probe mounting flange | 2.75" CF |
| ECU dimensions | 4.1" × 3.1" × 9.1" (WHD). Easily separated from the probe for bakeout. |
| Probe dimensions | See drawing |
| LED indicators | Power ON/OFF, filament ON/OFF, Electron multiplier ON/OFF, |

| | |
|--------------------|---|
| Warm-up time | RS-232 Busy, Error, Overpressure, Burnt Filament Peak height ±2% after 3 minutes. Mass stability ±0.1 amu after 30 minutes. |
| Computer interface | RS-232C, 28,800 baud with high-level command set |
| Software | Windows based application |
| Power | 24 VDC @ 2.5 amps. Male DB9 connector, optional built-in power module for AC line operation |
| Weight | 6 lbs. |
| Warranty | One year parts and labor on defects in materials and workmanship |

Ordering Information

| | |
|-----------|------------------------------------|
| CIS100/1 | 100 amu CIS w/ electron multiplier |
| CIS200/1 | 200 amu CIS w/ electron multiplier |
| CIS300/1 | 300 amu CIS w/ electron multiplier |
| Option 02 | AC power module |
| O100HJC | 200 °C heater jacket |
| O100REA | Ethernet adapter |
| O100TDP | Turbo pump/diaphragm pump |

| CIS Parameter | Range | CIS mode | RGA mode |
|---|-----------|----------------------|------------------|
| Electron emission current (mA) | 0 to 1 | 0.05 | 0.5 |
| Electron energy (eV) | 25 to 105 | 70 or 35 | 70 |
| Ion energy (eV) | 4 or 8 | 4 or 8 | 4 or 8 |
| Extraction voltage (V) | 0 to -150 | -50 (typ.) | -50 (typ.) |
| Sensitivity (A/Torr) (for N ₂ @ 28 amu) | | 10 ⁻⁶ | 10 ⁻⁵ |
| Linear range upper limit (Torr) | | 2 × 10 ⁻³ | 10 ⁻⁴ |
| MDPP (Torr) | | 10 ⁻⁸ | 10 ⁻⁹ |

Notes

1. The CIS tests were performed with a 70L/s hybrid turbomolecular pump, backed by a diaphragm pump, attached to the side port of the CIS Cover Tee.
2. The RGA mode sensitivities reported were calculated for N₂ at less than 10⁻⁵ Torr.
3. The CIS mode sensitivities were calculated for N₂ at 1 to 5 × 10⁻⁴ Torr.
4. MDPP (minimum detectable partial pressure) is determined by measuring baseline levels for Faraday cup detection in the presence of ²⁸N₂ at 10⁻⁵ (RGA mode) and 10⁻³ Torr (CIS mode). Up to 3 orders of magnitude improvement in detectability is possible when the electron multiplier is turned on.