

CMX998

Cartesian Feed-back Loop Transmitter IC

..... Transmitter Linearization for High Speed Data Systems

INN/998/1

www.cmlmicro.com

The CMX998

- Frequency Range: 100MHz to 1GHz
- Wide-Band Noise: -148dBc/Hz
- SPI Compatible C-BUS Serial Interface
- Forward Path Up Converter
- Reverse Path (Feedback) Down Converter
- System and Path Gain-Controls
- Error Amplifiers
- Selectable Open and Closed Loop Functions
- 360° Loop Phase-Shift Control
- Instability Detector
- Linearization Gains of 30dB or More Achievable
- Flexible Digital Interface (for CMX980A and CMX981)
- Available in a Q1 (64 no-leads) VQFN Package
- Low (3.0 to 3.6 volt) Power Requirement
- EV9980 EvKit is Available for IC Evaluation and Demonstration

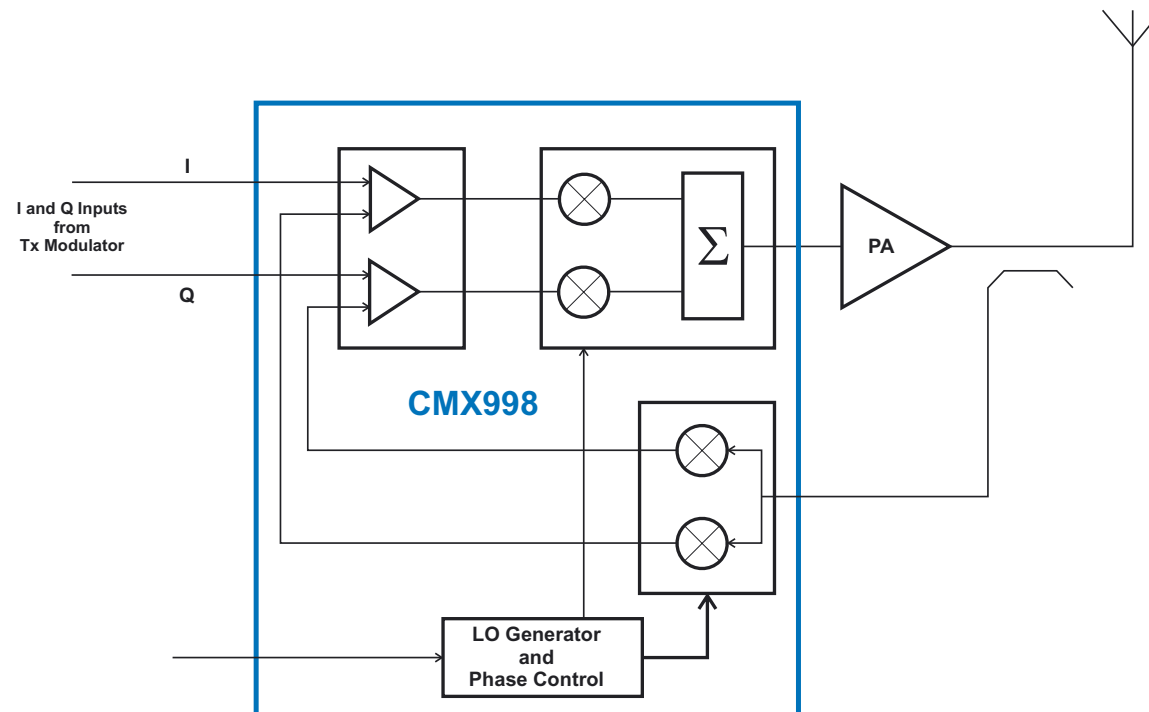

As a state-of-the-art design for an integrated CFBL, the CMX998 improves the efficiency and linearity of transmitters of non-constant envelope modulation by the use of a flexible Cartesian feed-back loop.

Consisting of an 'I' and 'Q' up-converter (modulator) in the forward (Tx) path and 'I' and 'Q' mixers in the feedback (Rx) path, the CMX998 makes available a complete collection of building-block type circuits on a single integrated circuit that the designer/user can select to perform all of the functions required to produce a clean, linear, Tx output signal in a wide-ranging RF spectrum.

Covering a wide RF range, from 100MHz to 1GHz, it is usable with channel bandwidths up to 150kHz.

The CMX998 offers high performance, low wide-band noise and a large degree of linearization gain. Typically, 30dB of linearization gain is achievable.

Available in a compact 64 no-leads VQFN package this product is an ideal companion for the CMX981 advanced digital radio baseband codec IC in digital radio designs.

CFBL Functions for:

- TETRA Terminals
- TETRA 2 Terminals
- APCO P25 Phase 2
- Aviation Systems
- Mobile Satellite Terminals
- Linear Modulation Schemes:
QPSK, pi/4 DQPSK, 8PSK, QAM, OFDM, F4FM
- Direct Interface to CMX981 and CMX980A

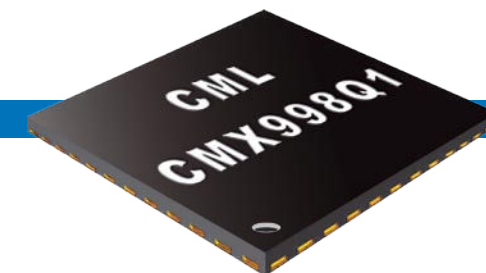

The CMX998

The Cartesian loop works to improve the linearity of the Tx Power Amplifier (PA) by the action of a feedback loop. The baseband I and Q format Tx input signal in the forward path and an I and Q demodulated feedback signal in the reverse path, developed from the RF PA output, are each applied to an error amplifier to form a negative feedback, closed-loop system that corrects RF PA distortion. The feedback I and Q demodulator local oscillator phase must be adjusted to align input and feedback I and Q signals.

Forward Path

The I and Q forward path of the IC each consists of differential input amplifier stages providing gain/attenuation, filtering and level translation via external components and for conversion to a single-ended format. I and Q differential error amplifiers are employed to produce the CFBL error signal by comparing the feedback signal with the reference modulation signal. The 'error' signal is a pre-distorted waveform that, when applied to the remainder of the forward path, will produce a perfect signal at the modulation output. The I and Q (up-converter) modulator provides translation from baseband signals to a low noise modulated RF signal. This stage also provides gain control.

Input Amplifiers

- For input signal processing
- Two of each for I and Q Tx channels
- Differential inputs
- Flexible configuration:
 - DC level translation
 - Filtering
 - Signal gain or attenuation

Error Amplifiers

- Compare reference signal with feedback signal
- Differential inputs
- Selectable functions via external components

Feature	Property
Supply Requirement	3.0 to 3.6 Volts
Frequency Range	100MHz to 1GHz
Wideband Noise Figure	-148dbc/Hz
Control	C-BUS - SPI Compatible Serial Interface
Package Style	Q1 64 No-Leads VQFN
Evaluation Resource	EV9980 EvKit

Up Converter I and Q Modulators

- Low noise output
- Baseband translation to RF
- Gain/attenuation settings

Feedback (Reverse) Path

The feedback path comprises a variable attenuator, I and Q mixer down-converter and baseband amplifiers and switching operations. Low-noise baseband amplifiers at the mixer outputs provide the correct gain to ensure that signal levels around the loop are optimised for noise and linearity. Various outputs are available at this stage to permit monitoring. The loop switches provide the ability to break the loop and operate in open-loop mode whilst simultaneously reducing the gain of the error amplifiers

Down Converter

- Low-noise, linear operation
- Variable attenuation input and output stages
- Broadband baseband path
- Minimum time-delay

Loop Switching

- Open/closed loop facilities
- Facilitates loop phase calibration

Instability Detector

- Detects out-of band energy
- Signal peak-hold facility
- Gain control and level shifter

Functions and Signal Flow

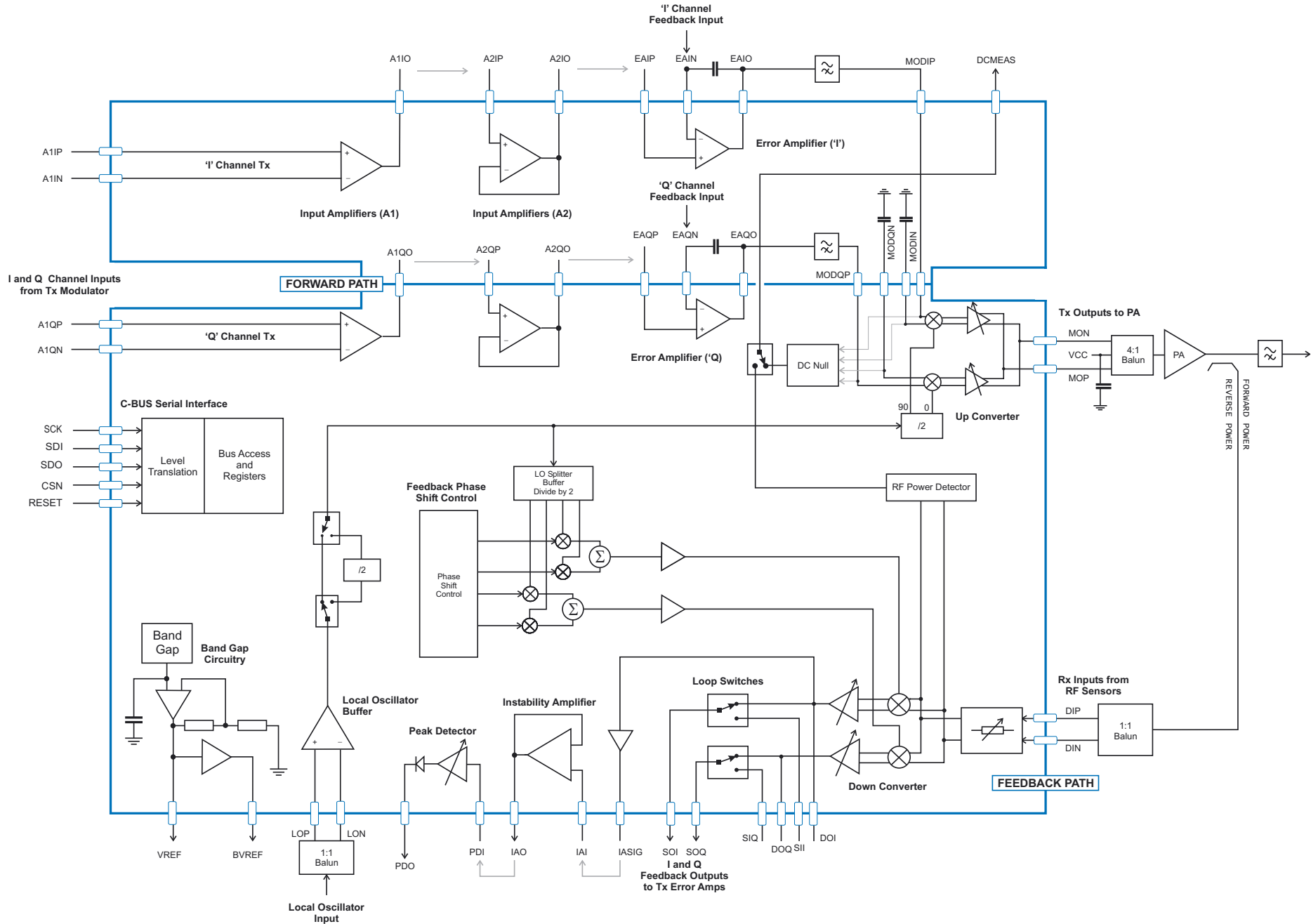

(a) Please note that with the exception of the band-gap circuitry, power supply inputs, outputs and components are not shown.

(b) Grey arrowheads shown on this diagram represent external, connecting circuitry, details of which are given in the product datasheet.

Evaluation, Experimentation and Design-in

The **EV9980** evaluation kit is available for evaluation and experimentation of the CMX998 and to reduce design-in time.

- Allows Full Evaluation of the CMX998
- Operational Frequency Range: 100MHz to 1GHz
- Complete Demonstration of CFBL Functionality (at 400MHz and 800MHz)
- Access to RF, Control and Baseband Signals
- Support and Interfacing for Customer PAs
- Differential or Single-ended I and Q Inputs
- 360° Loop Phase-Shift Control
- Interfaces to CMX981 EvKit
- Can Utilise PE0001 EvKit Interface

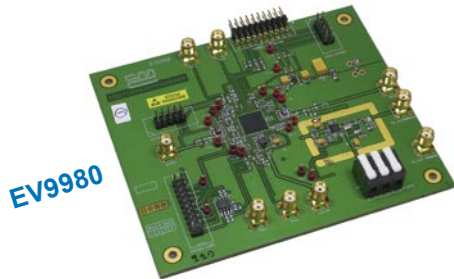

CMX998 Performance

Tx output spectrum in open loop and CMX998 closed loop operation

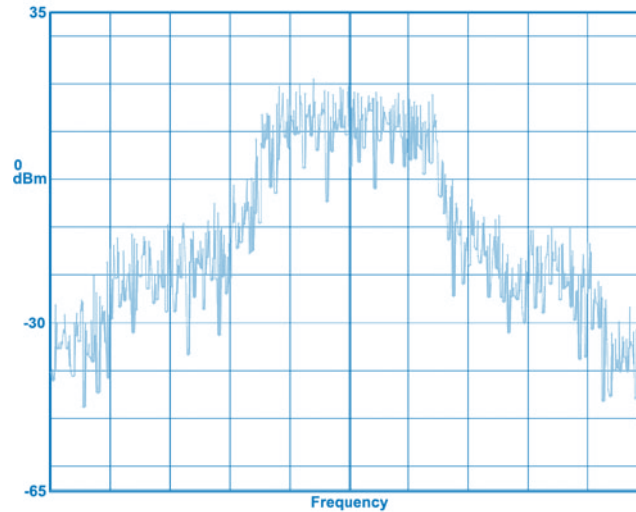

Open loop (no linearization) gives poor performance

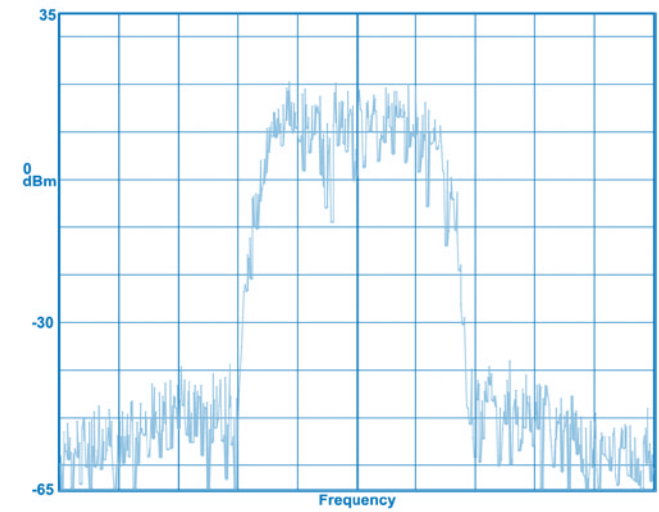

Closed loop (CMX998 linearization) gives much improved performance

Member Companies



**CML Microcircuits
(UK) Ltd**

COMMUNICATION SEMICONDUCTORS

Tel: +44 (0)1621 875500 Fax: +44 (0)1621 875600
sales@cmlmicro.com www.cmlmicro.com



**CML Microcircuits
(USA) Inc.**

COMMUNICATION SEMICONDUCTORS

Tel: +1 336 744 5050 and 800 638 5577 Fax: +1 336 744 5054
us.sales@cmlmicro.com www.cmlmicro.com



**CML Microcircuits
(Singapore) Pte Ltd**

COMMUNICATION SEMICONDUCTORS

Singapore
Tel: +65 67450426 Fax: +65 67452917
sg.sales@cmlmicro.com www.cmlmicro.com

Shanghai

Tel: +86 21 63174107 and +86 21 63178916 Fax: +86 21 63170243
cn.sales@cmlmicro.com.cn www.cmlmicro.com

A CML Microsystems Plc Company

The CMX998, the CMX981 and TETRA

The CMX998 fulfils the TETRA requirement. The TETRA standard is a good benchmark for a Cartesian feed-back loop as it calls for good linearity to achieve the required adjacent channel powers of up-to -60dBc.

The EV9980 can be configured, via a dedicated interface, to work alongside the CMX981 Advanced Digital Radio Baseband Processor or with a custom baseband system.

As an Advanced Digital Radio Processor IC compatible with the TETRA specification, the CMX981 includes both I and Q and auxiliary codecs, is compatible with the CMX998 and provides a specific DC offset correction register to calibrate out CMX998 DC offsets.

Your Local CML Distributor

Design Resources

Design and application support is available from: www.cmlmicro.com/

- IC and EvKit Technical Datasheets
- Function Image™ File Download
- Application Notes
- Frequently Asked Questions
- Application Support via local 'help' desks